

Description

The AC4 and AC4-CS Motor Controllers are compact, four-motor control boards designed to supply and switch a simultaneous maximum of 2.5 Amperes each to four motors operating on 115 Volts AC at 60 Hertz. The AC4-CS adds current sensing capability to allow for accurate positioning of motors based on calibrated run times, and for the detection of jammed motors by sensing excess current through the motor windings. The Master3-1 motor controller is designed to work in concert with three SL1 slave relays to provide similar functionality to the AC4. The Master3-1 and SL1 are designed to handle a maximum current of 5 Amperes. This document is focused on the AC4 but the features are similar for the AC4-CS and Master3-1 except where noted.

The AC4 is designed with eight on-board relays, actuated by an 8-bit low power microprocessor, and is typically used with bidirectional AC motors which require an AC voltage to be applied across two terminals. Separate motor windings are used for each direction. To protect the motor, the AC4 controller has been designed to insure that both windings are never energized simultaneously.

Input to the AC4 is 115VAC at up to 10 Amperes per controller. The current requirement is based on the size and distance to each motor. Typical current requirements for AC window shade motors are .5 – 2 Amperes. A 10 Ampere fast blow fuse protects the controller. The AC4-CS has additional current limiting protection that will shut down a motor if it is drawing excessive current. The Master3-1 is not fused.

Control input to the board may come from a number of devices, but is ultimately translated to a digital serial bus protocol. A total of 24 input channels are available. A channel can be thought of as a pair of buttons where each button of the pair activates one motor or a group of motors in a particular direction.

Various devices such as infrared remotes, radio frequency remotes, serial RS-232 devices, and others can be used to provide the serial bus with the control signals necessary to operate the AC controllers described in this manual. These devices are manufactured by RS Scene Automation and other vendors.



AC4

Features

- Each controller drives up to four 115 Volt bidirectional AC Motors
- Compact form factor,
- Programming simplicity with intuitive interface
- Controllable using up to 24 separate input channels (six input channels may be assigned per motor for the AC4 and AC4-CS) providing complete flexibility for individual, group and subgroup arrangements.
- Input devices include: IR Remote, RF Remote, wall mounted keypads and RS-232.
- Uses industry standard bus format with modular RJ-11 connectors.
- Controllers may be daisy-chained, allowing many motors to be controlled by one device.
- Programming mode indicated by both on-board LED and motor “jiggle” feedback, allowing programming to be performed in either the location of the controller or the location of the motors.
- Two piece screw terminals provide convenient motor connections for 12 – 18 gauge wire, reducing installation time and making troubleshooting easier.
- Programmable contact closure interface provides control of multiple motor groupings without jumper wires.
- Selectable local and global modes providing greater flexibility in complex multiple controller installations.
- Load sensing for intermediate stops and motor stall detection (AC4-CS).

System Warnings

- To reduce the risk of fire, electric shock, or injury to persons, installation work and electrical wiring must be done by qualified person(s) in accordance with applicable codes and standards.
- To reduce the risk of fire and electric shock, install this controller only with Listed window shade, projection screen or projector lift motors.
- Do not exceed the rated current of the motor controller which is listed on each controller.
- Motor controller(s) shall be mounted in Listed NEMA type metallic or nonmetallic enclosures.
- Suitable standoff posts (provided with the controller) shall be used when mounting into a metallic enclosure.

Installation

Four 0.125" (3.2mm) through-plated mounting holes are provided for mounting the AC4 and AC4-CS. The two holes on either side of the motor terminals are electrically connected to AC ground. Mounting must be performed within a NEMA Listed enclosure. Minimum enclosure dimensions for the AC4 and AC4-CS are 8" x 8" x 4". The supplied plastic spacers, ¼" (7mm) in length must be used to ensure that the rear of the board does not come into contact with any enclosure surface. Exterior installations must be performed within a waterproof Listed enclosure.

The AC4 can dissipate as much as 2.5 Watts. Adequate ventilation must be provided to ensure this amount of heat can be dissipated. This is a very small amount of heat and unless the AC4 is used in an insulated, confined space with no ventilation, should not normally be an issue.

The SL1 may be mounted into a single gang Listed junction box 8 cubic inches or larger. The Master3-1 may be mounted into a Listed enclosure 5" x 3.5" x 1.5". If the box is metallic then the spacers provided must be used.

All terminal blocks are designed for either stranded or solid wire, 12 – 20 AWG, and use a standard small screwdriver for installation. The AC power input terminals are labeled Hot (115VAC), Neut (neutral) and GND (AC ground). The motor output terminals are labeled with the appropriate motor number. Each motor has a four terminal connector labeled Neut (AC neutral), Clo (115VAC when activated in the **close** direction), Opn (115VAC when activated in the **open** direction) and GND (AC ground).

Multiple AC motors must **never** be connected in parallel. If this is done, the motor may be permanently damaged.

AC4 or AC4-CS 4 Motor Controller

This controller is intended for the control of motorized shades or projection screens. It has not been evaluated for the Standard for safety related controls UL991 and therefore is not considered suitable for entrapment protection. Reference manual.

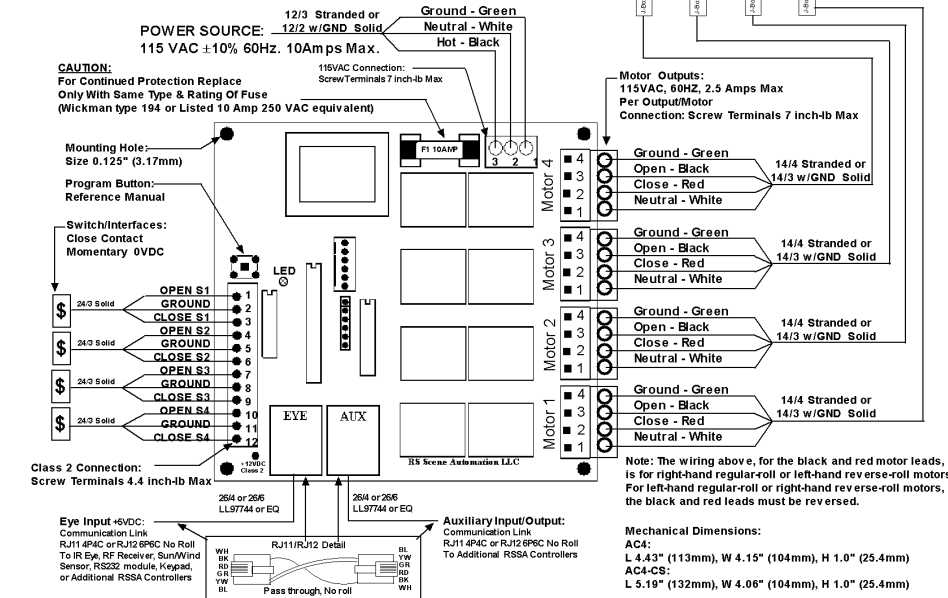

NOTE:

AC4 illustrated for reference. Typical four motor schematic for AC4 and AC4-CS series controllers. This board is to be mounted in a Listed enclosure using the standoffs provided. Two piece terminal connectors should be carefully removed, wired and then replaced one at a time. All line voltage shall be performed by a licensed electrician per local electrical code standards. Use copper conductors only. All field wiring to be permanent. To avoid the possibility of electrical shock, turn off the power to the controller when servicing. For further information on this product and wire sizing options reference the manual.



Master3-1 and SL1 Motor Controllers

These controllers are intended for the control of motorized shades or projection screens. They have not been evaluated for the Standard for safety related controls UL991 and therefore are not considered suitable for entrapment protection. Reference Manual.

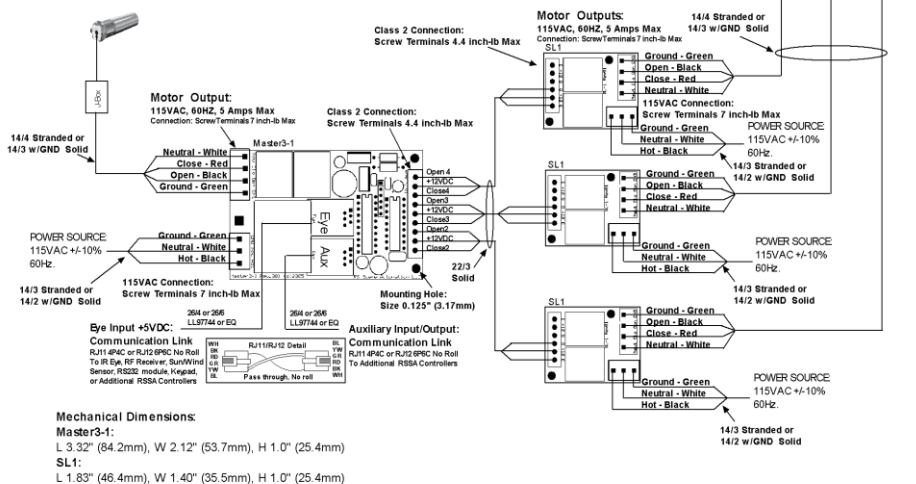

Note:

Typical four motor schematic for Master3-1 and SL1 series controllers. These boards are to be mounted in Listed enclosures using the standoffs provided. Two piece terminal connectors should be carefully removed, wired and then replaced one at a time. All line voltage shall be performed by a licensed electrician per local electrical code standards. All field wiring to be permanent. To avoid the possibility of electrical shock, turn off the power to the controller when servicing. For further information on these products reference the manual.

CONTROLLING MORE THAN FOUR MOTORS

The AC controllers have been designed to allow multiple units to communicate in situations where it is necessary to control more than four motors. When this arrangement is utilized, it is possible to program each AC controller such that a single command such as “OPEN 1” could control all, none, one, or a group of motors.

For example, a single 12 x 18 x 4 inch NEMA enclosure will hold six AC4 controllers. With the 24 input channels available, a system so configured would allow individual control of each motor as well as a master. If individual control is not desired, such a system could be controlled with an IR remote or keypad with less buttons than the full 24. Up to six channels can be assigned to a single motor using the AC4 and AC4-CS, while three channels can be assigned on the Master3-1.

To connect multiple units, a daisy chain approach is used. Make a connection from the “Aux” connector of one controller to the “Eye” connector of the next, and so on. A maximum of six AC4 units can be connected in this manner. “Eye” connectors must **never** be connected together. Remember, “motor controllers don’t see Eye to Eye”! Failure to heed this warning could result in poor operation or damage to the controller. This is because the “Eye” connector on each controller provides +5 VDC power to any devices which need to be powered. The power is the only difference between the “Eye” and “Aux” connectors. This means that it is possible to connect an “Aux” connector to another “Aux” connector. This approach is sometimes used at the end of a chain in order to make a powered connector available for an input device, such as an IR receiver.

The diagram on the next page shows how to connect and program multiple AC4’s in an 8 shade system with an IR eye and a keypad as inputs.

Eight Motor Programming Example

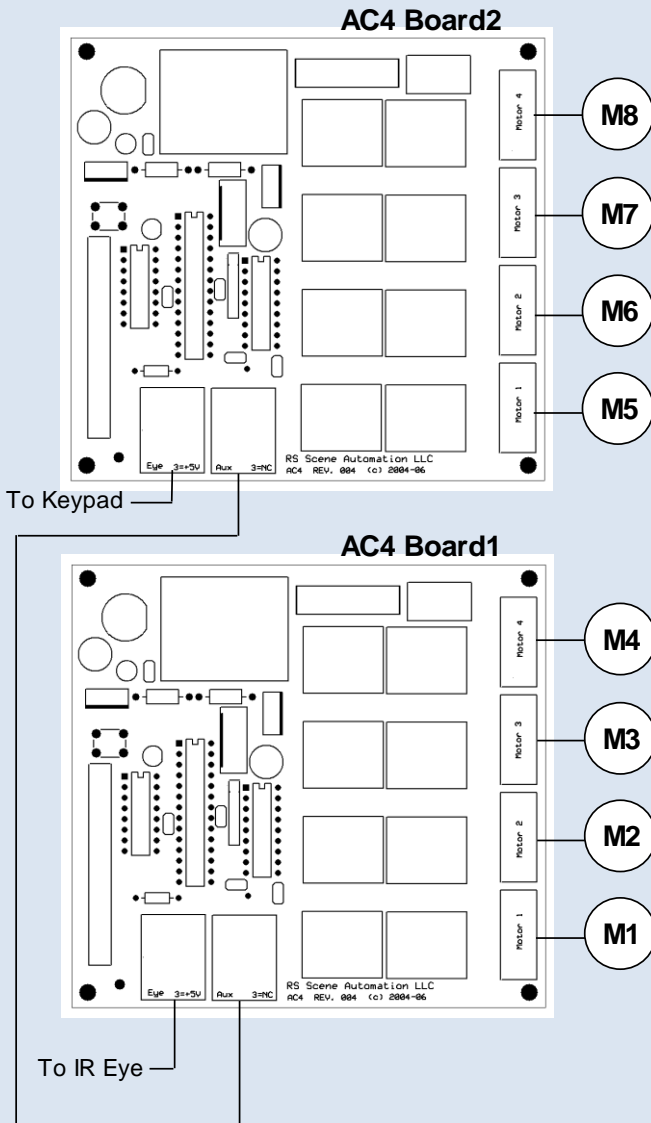

TO PROGRAM MOTOR GROUPINGS:

1. Press Program button on AC4 board or Stop+Open7+Close7
2. Press the motor number (Open1-4 corresponding to Motor1-4)
3. Press the channel numbers to be assigned
4. Press Stop to exit

Example Motor Grouping:

Channel1:=All motors M1-8
 Channel2:=Motors M5-8
 Channel3:=Motors M1, M3, M4
 Channel4:=Motor M2

To Program AC4 Board1 for this example:

M1=Motor1 Channels1&3 (Program, Open1, Open1, Open3, Stop)
 M2=Motor2 Channels1&4 (Program, Open2, Open1, Open4, Stop)
 M3=Motor3 Channels1&3 (Program, Open3, Open1, Open3, Stop)
 M4=Motor4 Channels1&3 (Program, Open4, Open1, Open3, Stop)

To Program AC4 Board2 for this example:

M5=Motor1 Channels1&2 (Program, Open1, Open1, Open2, Stop)
 M6=Motor2 Channels1&2 (Program, Open2, Open1, Open2, Stop)
 M7=Motor3 Channels1&2 (Program, Open3, Open1, Open2, Stop)
 M8=Motor4 Channels1&2 (Program, Open4, Open1, Open2, Stop)

WIRE SIZE SELECTION

Wires to motors must be carefully selected to assure system reliability. Wires that are too small or too long, particularly when connected to motors with heavy loads, can cause a drop in voltage which may result in a motor running too slow and may damage the motor over time. The wire may be either solid or stranded but must use copper conductors only.

Because wire selection is so important, we have provided charts below to estimate the size of wire required (assuming that the cable run length is known) or the maximum allowed length of wire (assuming the size of the wire is known).

These tables are to be used for estimation only.

Example 1:

When the cable length is known, and the current necessary to drive the motor is known, determine the wire size:

You are using a 2.0 Amp AC motor at 115 volts. Your cable run is 100 ft. Perform this calculation: $2.0 \times 100 = \mathbf{200.0}$ Look up 200 in the table. This value is between 282 and 176. Therefore you must use a cable containing 16 AWG or heavier wire. This assumes copper cable at 25° C (77 degrees F).

CALCULATION FOR 115 VOLT AC MOTORS	
BASED ON A 2% VOLTAGE DROP	
CABLE SIZE BASED ON MAXIMUM AMP FEET	
12 AWG	709 Amp-Feet
14 AWG	446 Amp-Feet
16 AWG	282 Amp-Feet
18 AWG	176 Amp-Feet

Example 2:

When the wire size is known, and the current necessary to drive the motor is known, determine the maximum cable length:

You are using a 1.5 Amp AC motor at 115 Volts. The motor manufacturer specifications state that the motor will operate correctly with a 2% voltage loss. You are using 18 AWG wire. To determine the maximum allowed cable length which will provide no more than a 2% voltage drop, find the wire size in the table above,

in this case 18 AWG. Compute the value specified: $176/1.5 = 117$ ft. The motor in this example draws a large current, and 18 AWG wire is relatively small, so to meet the motor manufacturer's specifications, it is necessary to use no more than about 117 feet of cable.

For situations which require other than a 2% drop, or those in which the wire is not at room temperature, it is necessary to perform more complex calculations than those shown here, using the appropriate wire resistance from accurate tables.

Operation

Command inputs to the AC controllers can come from a variety of sources, but each source ultimately provides commands to the controller via one of two methods: Digital devices such as keypads or remote control units will translate user input into the necessary digital serial protocol, which will be received by the controller through either the "Eye" or "Aux" RJ-11 connectors on the unit. Non-digital momentary contact devices such as a pushbutton wall switches are wired directly to the contact closure connectors on the board (AC4 and AC4-CS only).

In the discussion below, a **channel** can be thought of as a pair of buttons where each button of the pair activates a motor in opposing directions. Channels are typically labeled with the direction and channel number. The AC controllers described in this document support channels 1 – 24. Example: channel 1 consists of two buttons, OPEN 1 and CLOSE 1.

During normal operation, three types of commands are recognized:

- Commands which operate on all defined channels
- Commands which operate on a single channel
- Commands which program the AC controllers

ALL CHANNEL COMMANDS

Exactly three commands will operate on all channels simultaneously. These commands are typically labeled: "ALL OPEN", "ALL CLOSE" and "ALL STOP". The functions of these commands are described below.

ALL STOP

All motors will be immediately deactivated, regardless of any previous state or programming.

ALL OPEN / ALL CLOSE

Any motor which has at least one channel assigned to it will be activated in the direction specified. The motor will be energized for one minute. For the AC4-CS, the motor will stop if over-current is detected.

SINGLE CHANNEL COMMANDS

Programming the controller will allow an installer to associate a channel with none, one, or a set of motors. If no motor is associated with a given channel *n*, then a single channel command will have no effect. For all motors which are associated with channel *n*, the behavior of sending a single channel command to the unit is shown below. Note that an AC4-CS will stop any motor when excess current draw is detected, such as when a motor becomes stuck during operation. The current limit for this process is set during the calibration of the AC4-CS, which is described elsewhere in this document.

Note that for controllers having an available contact closure connector (AC4 and AC4-CS), each contact connector can be associated with no more than one channel. When associated with a channel, a contact closure event will function in the same way as a command received through the serial (“Eye” or “Aux”) connector. When not associated with a channel, a closed connection will have no effect. The one exception is that even if not associated with a channel, shorting the “open” and “close” terminals simultaneously to ground will send an ALL STOP command.

OPEN *n*

If a motor is currently activated in the OPEN direction, deactivate it. If a motor is currently activated in the CLOSE direction, deactivate the motor, then activate it in the OPEN direction for one minute. If a motor is currently deactivated, activate it for one minute in the OPEN direction.

CLOSE *n*

If a motor is currently activated in the CLOSE direction, deactivate it. If a motor is currently activated in the OPEN direction, deactivate the motor, then activate it in the CLOSE direction for one minute. If a motor is currently deactivated, activate it for one minute in the CLOSE direction.

Hardware Specifications

- Controls up to four 115 Volt AC Motors at 2.5 Amps max per motor (5 Amps for the Master3-1 and SL1).
- Dimensions:

AC4	L 4.43" (113mm), W 4.15" (104mm), H 1.0" (25.4mm)
AC4-CS	L 5.19" (132mm), W 4.06" (104mm), H 1.0" (25.4mm)
Master3-1	L 3.32" (84mm), W 2.12" (54mm), H 1.0" (25.4mm)
SL1	L 1.82" (46mm), W 1.38" (35mm), H 1.0" (25.4mm)
- Control inputs: Serial 5 Volt digital two wire bus. Control inputs may be supplied on the "Eye" connector, an RJ-11, or on the "Aux" connector, also an RJ-11. Signal and ground on these connectors are wired in parallel, but the "Eye" connector supplies power from the unit at +5VDC.
- RJ-11 color code interface is as follows:

Red	+5 volts output to powered device (pin3 Eye jack only)
Black	DC Ground (pin2)
Yellow	Bidirectional control signal bus (pin5)
- Contact closure inputs (AC4 and AC4-CS only): 4 programmable contact closure inputs provided through a 12 conductor header. Momentary contact switch or dry contact closure activates any group of motors. Inputs may be selected to be controller-specific or to communicate action between controllers via the serial bus.
- Screw connectors for power and motor accept AWG 12 – 18 gauge stranded or solid wire.
- Mounting hole size 0.125" (3.17 mm)
- Fuse (AC4 and AC4-CS only): 250Volt 10 Amp fast blow (Wickmann 1942100000)
- Maximum operating temperature: 40° C ambient.
- Nominal power consumption when no motor or relay is activated: < 1 Watt

LIMITED WARRANTY FOR MOTOR CONTROLLERS

RS Scene Automation, LLC, ("RSSA") warrants that the motor controllers sold by RSSA, or by either a distributor or representative authorized by RSSA to sell motor controllers manufactured by RSSA, are free from Manufacturing Defects (as defined and as determined below) for a period of one (1) year when properly installed in an original installation by a professional installer, subject to and on the terms and conditions set forth in this Limited Warranty.

RSSA will remedy and correct any "Manufacturing Defects," with respect to the Motor controllers, during the Warranty period, by, at RSSA's sole option, either: (a) replacing, at RSSA's cost and expense, the Motor controller(s) with the same or substantially similar specifications; or (b) repairing the Motor controller(s), provided that (in addition to any other requirements or provisions of this Limited Warranty), the customer returns, with all shipping costs pre-paid at the customer's sole expense, the Motor controller(s) that the customer claims are subject to any Manufacturing Defects according to RSSA'S Returned Merchandise Authorization procedures, as they may exist from time to time.

RSSA is the only party authorized to remedy and correct any Manufacturing Defects as provided by this Limited Warranty, and this Limited Warranty does not apply to replacements of Motor controller(s), or any other corrective or remedial action with respect to the Motor controller(s), made by any other party.

Definition of "Manufacturing Defects." "Manufacturing Defects" means RSSA verified problems or defects resulting from the manufacture, materials, or workmanship of the Motor controller(s) by RSSA that render(s) the Motor controller(s) unable to function in a manner consistent with and according to the specifications provided by and/or defined by RSSA that are applicable to the Motor controller(s). Furthermore, RSSA specifically reserves the right to: (a) determine, in its sole, absolute discretion, whether a "Manufacturing Defect(s)" exists; and (b) decline any claim under this Limited Warranty with respect to a Motor controller that RSSA can not verify, in its sole, absolute discretion, was sold to the Limited Warranty claimant either directly by RSSA or through an RSSA authorized distributor or representative. Notwithstanding the foregoing, and without limiting the foregoing, "Manufacturing Defects" are NOT unconfirmed defects or problems caused by modifications to, or work performed on, the Motor controller(s) by any party after the sale by RSSA. In addition, "Manufacturing Defects" are NOT unconfirmed defects or problems caused by utilization of the Motor controller(s) in a manner inconsistent with the specifications provided and/or defined by RSSA that are applicable to the Motor controller(s), or in any unreasonable manner. RSSA reserves the right to void this Limited Warranty, and shall not be obligated to make any replacement or repair to a motor controller in the event that work is performed on the Motor controller(s) by any party after the sale by RSSA, or if the Motor controller(s) are used in a manner inconsistent with the specifications provided and/or defined by RSSA that are applicable to the Motor controller(s), or are used in an unreasonable manner.

EXCEPT AS SET FORTH IN THIS LIMITED WARRANTY, RSSA MAKES NO OTHER WARRANTIES, EITHER EXPRESS OR IMPLIED. FURTHERMORE, RSSA SHALL NOT BE LIABLE FOR ANY DAMAGES (WHETHER CONSEQUENTIAL, INCIDENTAL OR OTHERWISE) FOR ANY BREACH OF THIS LIMITED WARRANTY, EXCEPT FOR RSSA'S OBLIGATIONS TO REPLACE OR REPAIR, THE MOTOR CONTROLLER(S), AS ELECTED BY RSSA AT RSSA'S SOLE OPTION, AND AS MORE PARTICULARLY PROVIDED BY THIS LIMITED WARRANTY, AND SUCH REPLACEMENTS OR REPAIR, AS THE CASE MAY BE, SHALL BE THE SOLE REMEDY FOR ANY SUCH BREACH BY RSSA OF THIS LIMITED WARRANTY.